

Monobloc and Sectional Directional Control Valves

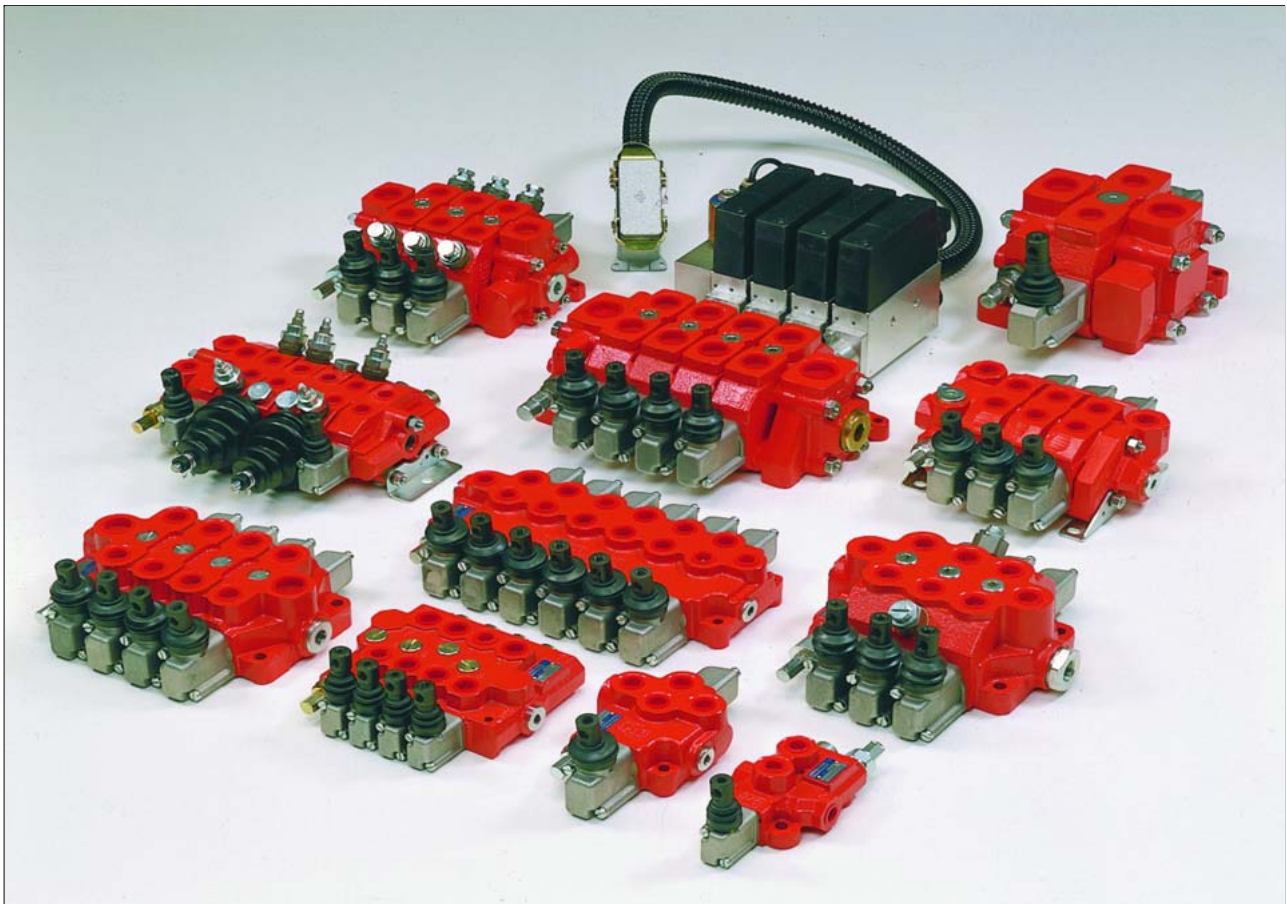

motion and progress

4 Monobloc directional control valves HDM11S



Contents

4.1	General specifications	31
4.2	Dimensional data	32
4.3	Performances curves	33
4.4	Monobloc bodies	34
4.5	Adjustable direct acting - Relief Valve RV	39
4.6	Spool charts	39
4.7	Load Sensing	40
4.8	Spool positioners	40
4.9	Lever styles	44
4.10	Port relief and anti-cavitation valves	46
4.11	Hydraulic-Pneumatic control ON-OFF	47

4.1 General specifications

Technical specification		
Max flow rate	l/min U.S.G.P.M.	45 12
Max continuous operating pressure supply port P Parallel circuit	bar PSI	350 5000
Max intermittent peak pressure work port A/B Parallel circuit	bar PSI	400 5800
Max back pressure tank port T	bar PSI	30 430
Oil temperature	° C ° F	-10 to 80 14 to 180
Oil viscosity	mm ² /s	16 to 75
Oil filtration	μ	≤ 30

Spool leakage at 100 bar (1450 PSI), Temp. 50° C (120° F), viscosity 27 mm ² /s:		
Maximum	cm ³ /min Cu. In./min	12 0.732
Average	cm ³ /min Cu. In./min	6 0.366
Lower values on demand (to be agreed with our Sales Dept..)		

Number of spools	1 to 6
Adjustable direct operated relief valve (tamper-proof seal available on request)	RV
Load hold check valve in each section	LC
Cartridge Anti-Shock Anti-cavitation and service relief valve	OA-UC-C
Mechanical release check valve	RSM3

4.1.1 Weight (standard version; without options)

Version	kg	lb
HDM11S/1	3.5	7.7
HDM11S/2	5.2	11.45
HDM11S/3	6.9	15.20
HDM11S/4	8.6	18.94
HDM11S/5	10.3	22.69
HDM11S/6	12	26.43

4.1.2 Material specification:

Body: High strength cast-iron.
Spool: Hardened steel and chrome plated
Seals: Buna "N".

4.1.3 Standard features:

- 1) Parallel circuit
- 2) Balanced interchangeable spools (provides minimum leakage, smooth operation)
- 3) Wide selection inlets, work ports, and outlets threaded ports.
- 4) Negative overlapping of the spool.

4.1.4 Optional features available:

- 1) Open or closed centre positions, 3 or 4 way operations, 3 or 4 position (float position), full open centre (motor spool) and other spool options.
- 2) Carry over.
- 3) Series circuit
- 4) Load Sensing circuit closed centre for variable displacement pump
- 5) Complete lever assembly
- 6) Wide range of positioners

4.1.5 Symbols:

P: inlet port
T: outlet port
A/B: work ports
H.P.C.O.: carry-over
RV: relief valve
P₁T₁: side inlet and outlet ports
 3.1.0.2: spool position
P: pressure line
T: exhaust line
E: centre line (by pass).

4.2 Dimensional data

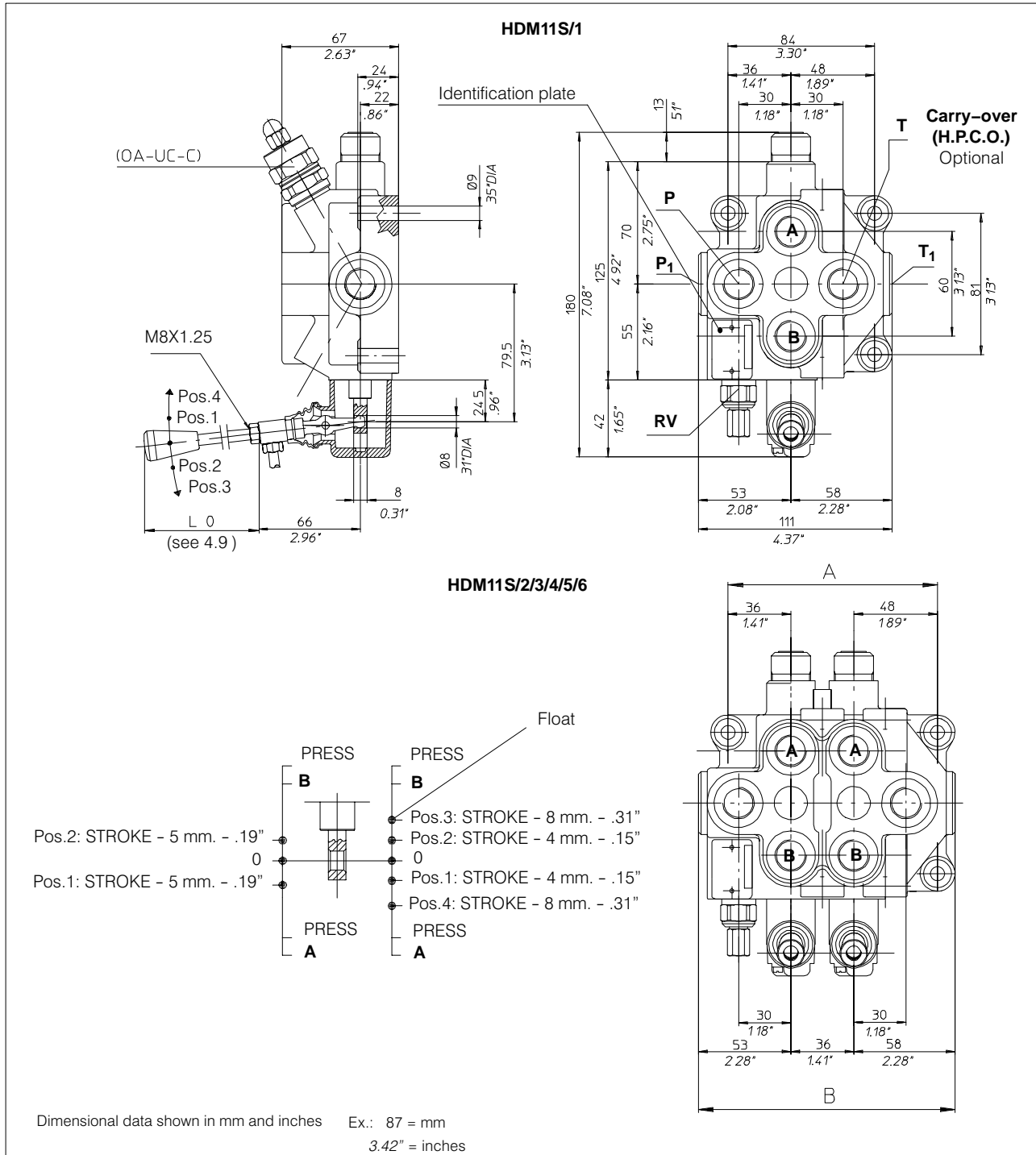

N. of sections		HDM11S/2	HDM11S/3	HDM11S/4	HDM11S/5	HDM11S/6
Dimension	A	120	156	192	228	264
		4.72"	6.14"	7.56"	9.98"	10.40"
	B	147	183	219	255	291
		5.78"	7.20"	8.62"	10.04	11.45"

4.3 Performance curves

Oil: Shell Tellus T37
 Temperature: 50° C (120° F)
 Viscosity: 27 mm²/s

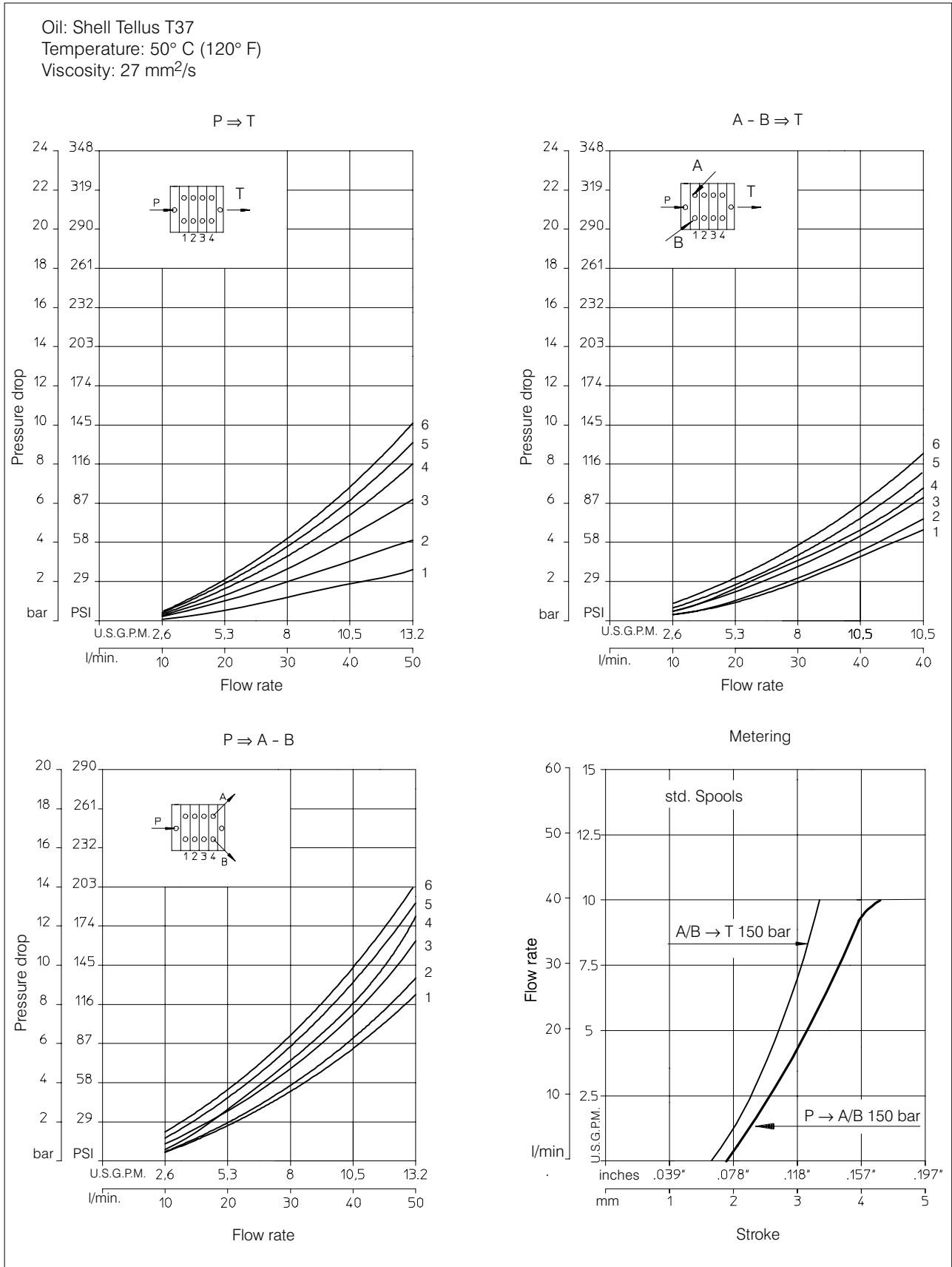

4.4 Monobloc bodies

4.4.1 Standard circuit: parallel
Open center with P – T – RV (Standard)

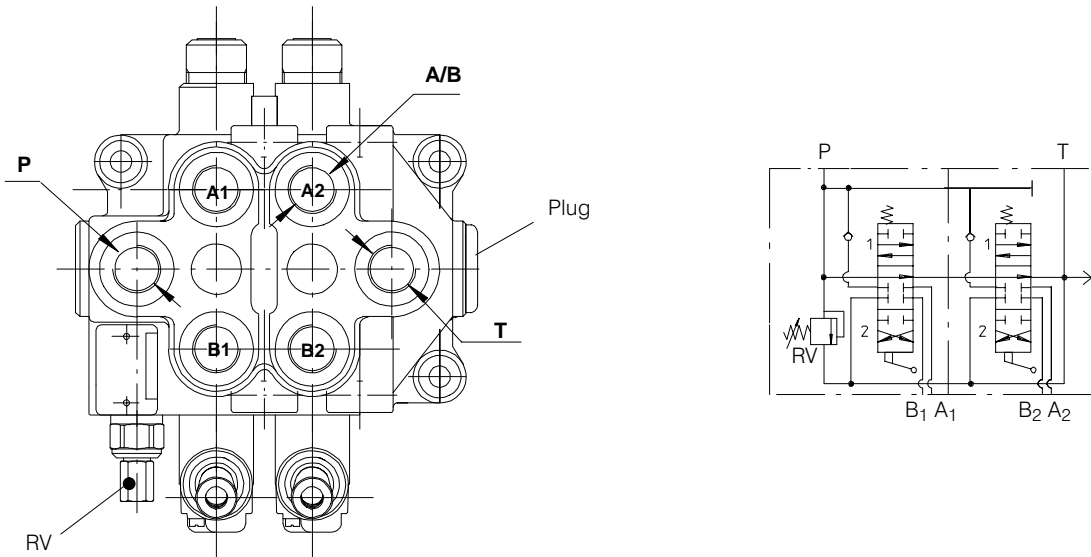

P-T A/B	Type/Code					
	HDM11S/1	HDM11S/2	HDM11S/3	HDM11S/4	HDM11S/5	HDM11S/6
SAE 6	K01	K01	K01	K01 200.9434.6005.0	K01	K01
SAE 8	K02 200.9431.7004.0	K02 200.9432.7006.0	K02 200.9433.7006.0	K02 200.9434.7006.0	K02 200.9435.7006.0	K02
3/8" BSP	K04 200.9431.2018.0	K04 200.9432.2048.0	K04 200.9433.2056.0	K04 200.9434.2036.0	K04 200.9435.2027.0	K04 200.9436.2014.0
M18X1.5	K05 200.9431.1024.0	K05 200.9432.1045.0	K05 200.9433.1045.0	K05 200.9434.1027.0	K05 200.9435.1020.0	K05 200.9436.1012.0

P-T A/B	Section with valve UC-OA-C -Type/Code					
	HDM11S/1	HDM11S/2	HDM11S/3	HDM11S/4	HDM11S/5	HDM11S/6
SAE 6	K06	K06	K06	K06	K06	K06
SAE 8	K07 200.9431.7005.0	K07 200.9432.7007.0	K07 200.9433.7007.0	K07 200.9434.7007.0	K07 200.9435.7007.0	K07 200.9436.7006.0
3/8" BSP	K09 200.9431.2020.0	K09 200.9432.2050.0	K09 200.9433.2057.0	K09 200.9434.2037.0	K09	K09
M18X1.5	K10 200.9431.1023.0	K10 200.9432.1046.0	K10 200.9433.1046.0	K10 200.9434.1028.0	K10 200.9435.1021.0	K10 200.9436.1013.0

Note 1: Body codes consist of: machined casting, seals, plugs and check valve only. Not to be used for complete valve order.

Note 2: For availability of -K- bodies without ordering code please contact our Sales Department.

Note 3: 1/2" BSP size ports are available only under demand. Please take care that max continuous operating pressure must not exceed 180 bar.

4.4.2 Standard circuit: parallel
Open centre and carry-over with P – T1 – R
H.P.C.O.

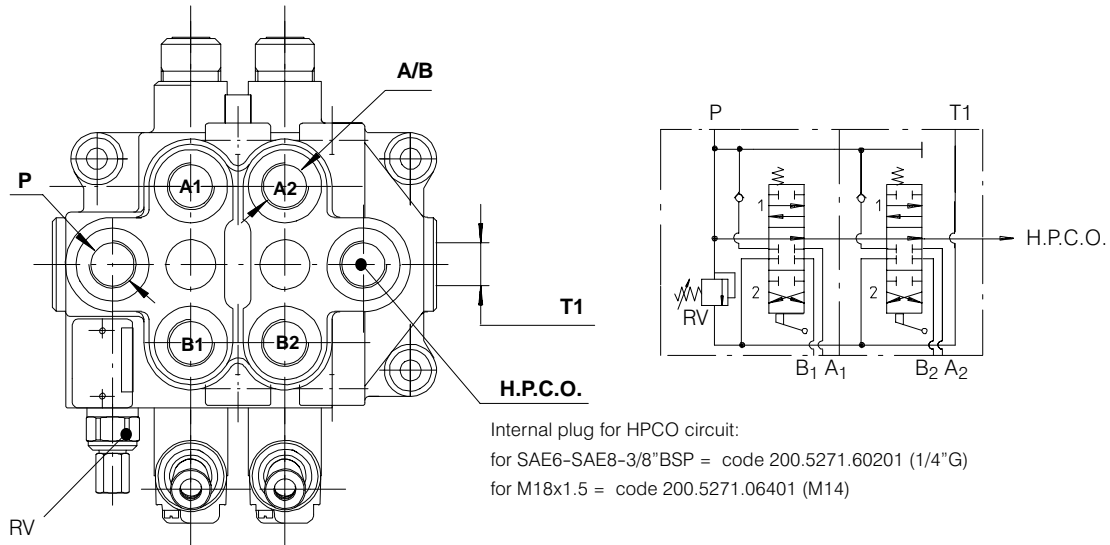

P-T1 A/B	Type/Code					
	HDM11S/1	HDM11S/2	HDM11S/3	HDM11S/4	HDM11S/5	HDM11S/6
SAE 6	K11	K11	K11	K11	K11	K11
SAE 8	K12 200.9431.7006.0	K12 200.9432.7008.0	K12 200.9433.7008.0	K12 200.9434.7004.0	K12	K12
3/8" BSP	K14 200.9431.2019.0	K14 200.9432.2049.0	K14 200.9433.2054.0	K14 200.9434.2038.0	K14	K14
M18X1.5	K15 200.9431.1025.0	K15 200.9432.1043.0	K15 200.9433.1051.0	K15 200.9434.1029.0	K15	K15

P-T1 A/B	Section with valve UC-OA-C - Type/Code					
	HDM11S/1	HDM11S/2	HDM11S/3	HDM11S/4	HDM11S/5	HDM11S/6
SAE 6	K21	K21	K21	K21	K21	K21
SAE 8	K22 200.9431.7007.0	K22 200.9432.7009.0	K22 200.9433.7009.0	K22 200.9434.7009.0	K22	K22
3/8" BSP	K24 200.9431.2021.0	K24 200.9432.2051.0	K24 200.9433.2055.0	K24 200.9434.2039.0	K24	K24
M18X1.5	K25 200.9431.1026.0	K25 200.9432.1044.0	K25 200.9433.1052.0	K25 200.9434.1030.0	K25	K25

Note 1: Body codes consist of machined foundry, seals, plugs and check valve only. Not to be used ordering a complete valve
 Note 2: For availability of -K- bodies without ordering code please contact our Sales Department.
 Note 3: 1/2" BSP size ports are available only under demand. Please take care that max continuous operating pressure must not exceed 180 bar.

4.4.3 Optional circuits: series and tandem
Open centre with P – T – RV

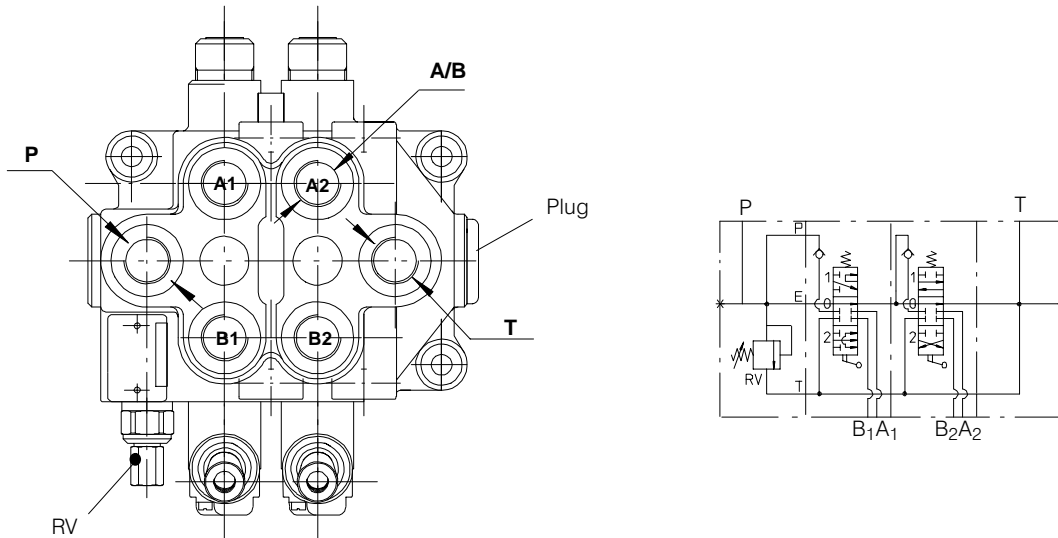

P-T A/B	Type/Code				
	HDM11S/2	HDM11S/3	HDM11S/4	HDM11S/5	HDM11S/6
SAE 6	K31	K31	K31	K31	K31
SAE 8	K32	K32	K32	K32	K32
3/8" BSP	K34	K34 200.9433.2058.0	K34 200.9434.2040.0	K34	K34
M18X1.5	K35 200.9432.1047.0	K35 200.9433.1054.0	K35 200.9434.1031.0	K35	K35

P-T A/B	Section with valve UC-OA-C - Type/Code				
	HDM11S/2	HDM11S/3	HDM11S/4	HDM11S/5	HDM11S/6
SAE 6	K36	K36	K36	K36	K36
SAE 8	K37	K37	K37	K37	K37
3/8" BSP	K39	K39 200.9433.2059.0	K39 200.9434.2041.0	K39	K39
M18X1.5	K40 200.9432.1048.0	K40 200.9433.1055.0	K40 200.9434.1032.0	K40	K40

Note 1: Body codes consist of machined foundry, seals, plugs and check valve only. Not to be used ordering a complete valve

Note 2: For availability of -K- bodies without ordering code please contact our Sales Department.

Note 3: 1/2" BSP size ports are available only under demand. Please take care that max continuous operating pressure must not exceed 180 bar.

4.4.4 Optional circuit: load sensing
 Closed centre for variable-displacement pump
 with P – T1– RV and L.s.

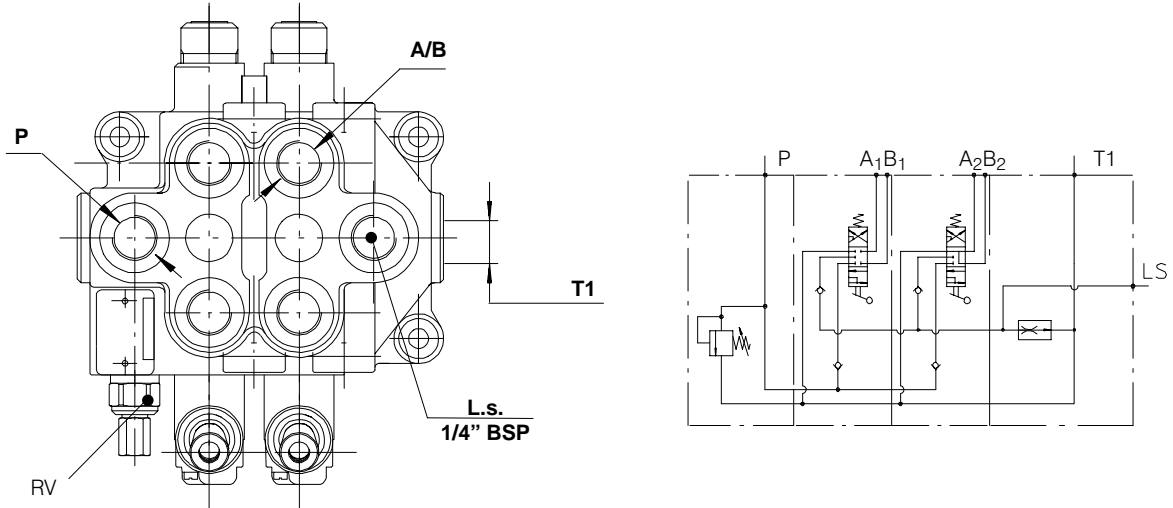

P-T1 A/B	Type/Code					
	HDM11S/1	HDM11S/2	HDM11S/3	HDM11S/4	HDM11S/5	HDM11S/6
SAE 6	K51	K51	K51	K51	K51	K51
SAE 8	K52	K52	K52 200.9433.7014.0	K52	K52	K52
3/8" BSP	K54	K54	K54	K54	K54	K54
M18X1.5	K55	K55	K55	K55	K55	K55

P-T1 A/B	Section with valve UC-OA-C - Type/Code					
	HDM11S/1	HDM11S/2	HDM11S/3	HDM11S/4	HDM11S/5	HDM11S/6
SAE 6	K56	K56	K56	K56	K56	K56
SAE 8	K57	K57	K57	K57	K57	K57
3/8" BSP	K59	K59	K59	K59	K59	K59
M18X1.5	K60	K60	K60	K60	K60	K60

Note 1: Body codes consist of machined foundry, seals, plugs and check valve only. Not to be used ordering a complete valve
 Note 2: For availability of -K- bodies without ordering code please contact our Sales Department.
 Note 3: 1/2" BSP size ports are available only under demand. Please take care that max continuous operating pressure must not exceed 180 bar

4.4.5 Check valves with mechanical release RSM3

The check valve taper seal is released by means of a taper on the spool and by a push rod.

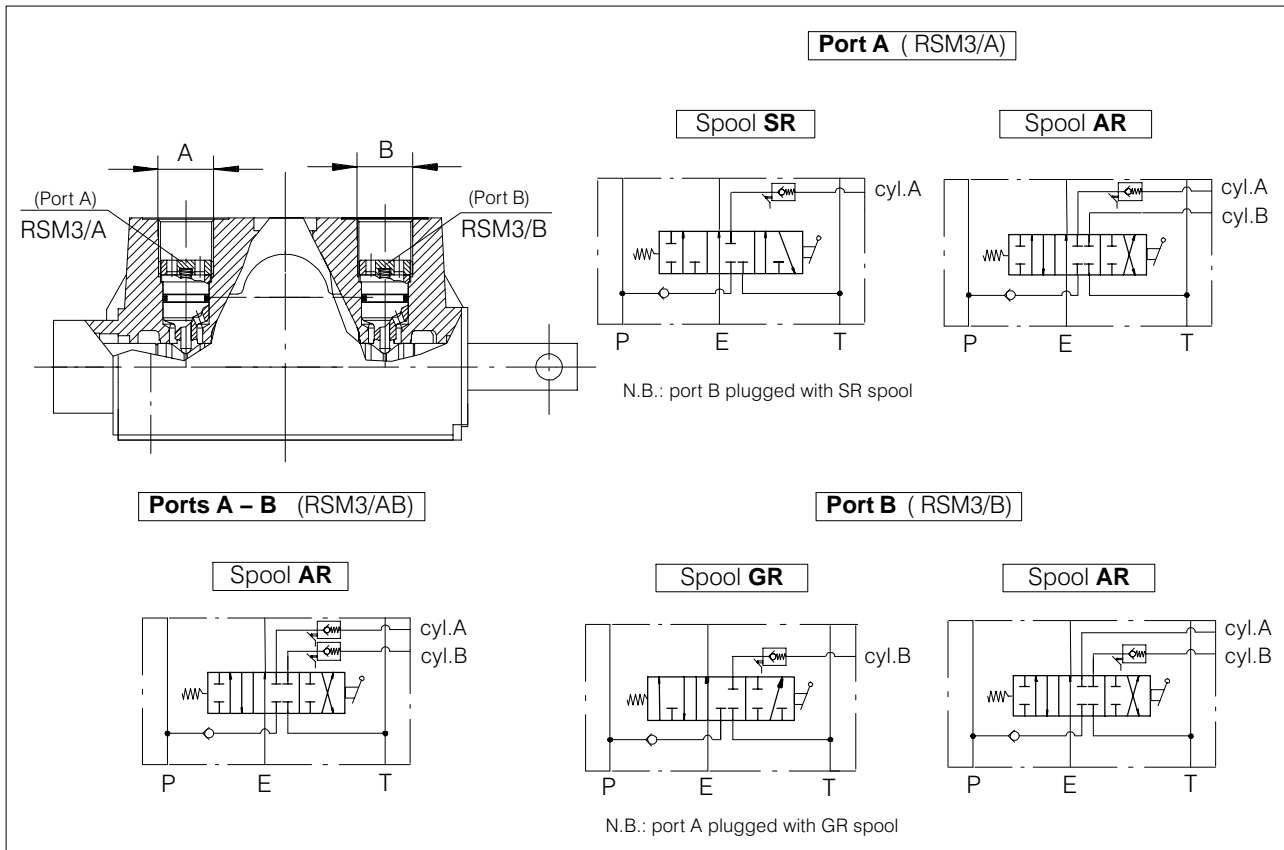

7A.1.1 Directional control valve bodies for RSM3 valve

A/B	Type/Code						RSM3 Code
	HDM11S/1	HDM11S/2	HDM11S/3	HDM11S/4	HDM11S/5	HDM11S/6	
SAE 8	K82	K82	K82	K82	K82	K82	
3/8" BSP	K84 200.9431.2022.0	K84	K84	K84	K84	K84	200.7876.0234.1
M18X1.5	K85 200.9431.1027.0	K85	K85	K85	K85	K85	200.7876.0229.1

A/B	Section with valve UC-OA-C - Type/Code						RSM3 Code
	HDM11S/1	HDM11S/2	HDM11S/3	HDM11S/4	HDM11S/5	HDM11S/6	
SAE 8	K92	K92	K92	K92	K92	K92	
3/8" BSP	K94	K94	K94	K94	K94	K94	200.7876.0234.1
M18X1.5	K95	K95	K95	K95	K95	K95	200.7876.0229.1

Note 1: Body codes consist of machined foundry, seals, plugs and check valve only. Not to be used ordering a complete valve
 Note 2: For availability of -K- bodies without ordering code please contact our Sales Department.
 Note 3: RSM3 check valve for SAE6 bodies is not available.

4.5 Adjustable direct acting Relief Valve RV

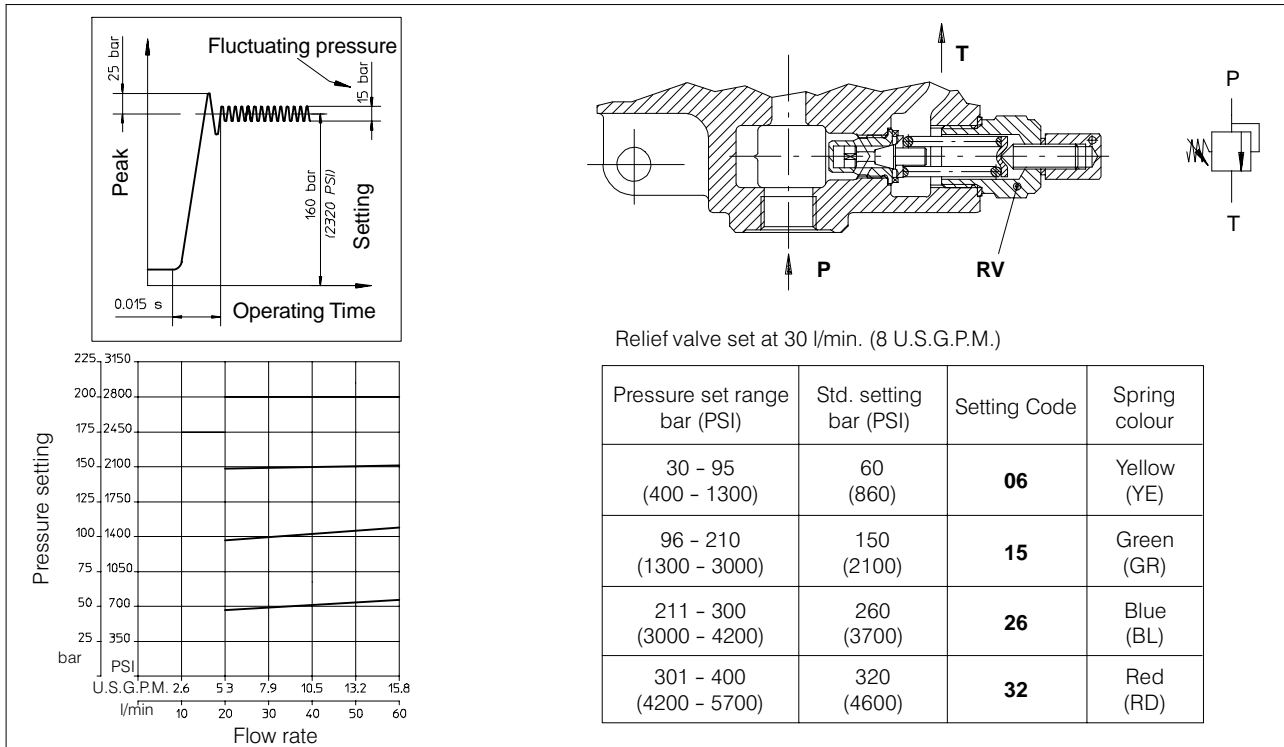

4.6 Spool charts

Spool scheme	Spool features	Type
	4 way - 3 position A/B closed E open by pass	A AR**
	4 way - 3 position A/B-E closed	B
	4 way - 3 position A/B to tank in neutral E open by pass	C
	4 way - 3 position A closed B to tank in neutral	D
	3 way - 3 position B closed E open by pass	G GR**
	4 way - 3 position B closed A to tank in neutral	L
	4 way - 3 position with differential spool in 2 nd position	R**
	3 way - 3 position A closed E open by pass	S SR**

	4 way - 3 position series connection	X
	4 way - 3 position A/B to tank in neutral series connection	XC
	4 way - 4 position 4 th floating position	Z
	4 way - 4 positions 4 th floating position	* WW
	4 way - 3 position A/B closed Load Sensing	** LSA
	4 way - 3 position A/B to tank in neutral Load Sensing	** LSC
	3way - 3 position B closed Load Sensing	** LSG
	3 way - 3 position A closed Load Sensing	** LSS

Note: For availability of L/S versions please contact our Sales Department
 * "WW": special body required (K...), positioner (240) and lever (L192)
 **: special body required (please contact our Sales Dept..)

4.7 Load Sensing

Load-sensing control and working principle

Through the use of variable flow pumps provided with a pressure and flow compensator the pressure and flow parameters can be adapted according to the different and real working conditions.

These pumps require the use of special valves provided with Load Sensing control which “feels” the hydraulic components (cylinder and motor) requirements and through a special pilot line (L.S.) controls the pump compensator conforming capacity and pressure to such requirements which can be variable in time within the limits of the pump performance.

The Load Sensing brings following advantages:

- a) Energy saving.
- b) Smaller heat exchangers can be used due to a smaller heat energy dissipation.
- c) Longer life of the pump and driving motor, due to reduced heavy working cycles.
- d) Excellent control of the load by using 100% of the spool metering.

The L.s. option requires specific bodies and spools. Please ask to Bucher Hydraulics S.p.A. for their availability

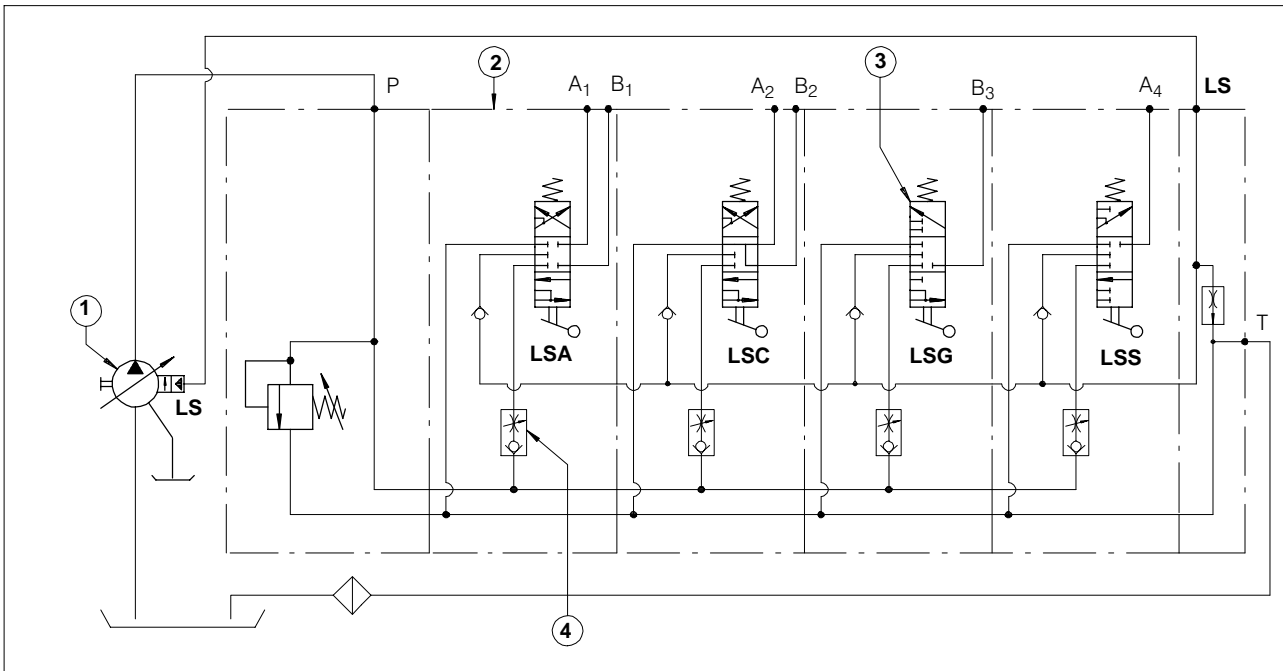

- 1) Variable flow pump provided with pressure and flow compensator.
- 2) Load Sensing valve.

- 3) Special spools: LSA – LSC – LSG – LSS
- 4) Check valve provided with max flow control

4.8 Spool positioners

F (N)**	Type	Code*
200	01 standard	200.7685.1001.0
140	79	200.7685.1092.0

3 position spring return to neutral

Type	Code*
02	200.7685.3001.0

2 position detent - spring center

* : code without plastic plug; plastic plug code: 200.6780.0008.0
Code F (N)**: force in Newton (N) needed to operate the spool

Type 03	Code* 200.7685.2001.0
-------------------	--------------------------

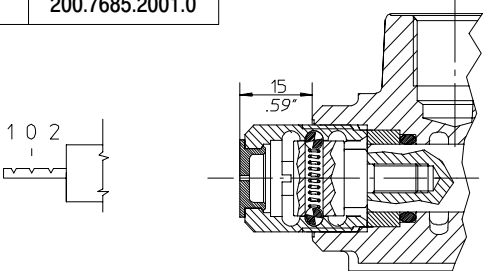

3 position detent

Type 04	Code 200.7685.4003.0
-------------------	-------------------------

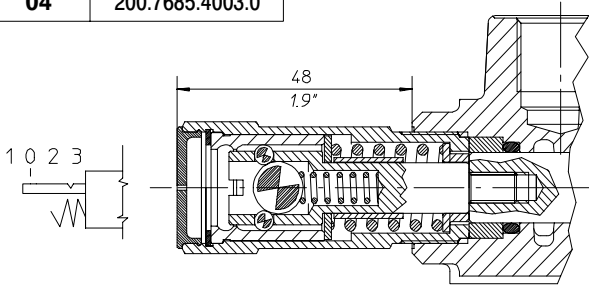

4 position float Plastic plug code: 200.6780.0009.0

Type 05	Code* 200.7685.2005.0
-------------------	--------------------------

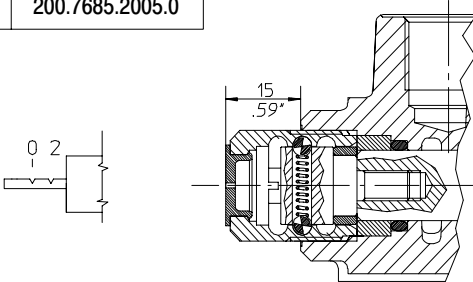

2 position detent

Type 06	Code* 200.7685.1005.0
-------------------	--------------------------

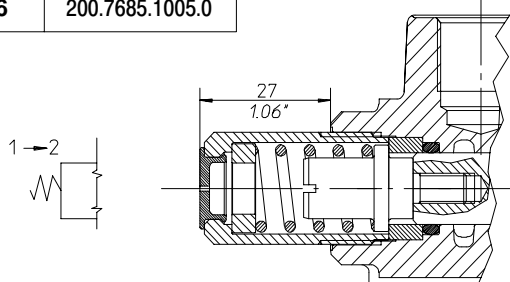

2 position spring return

Type 07	Code* 200.7685.2027.0
-------------------	--------------------------

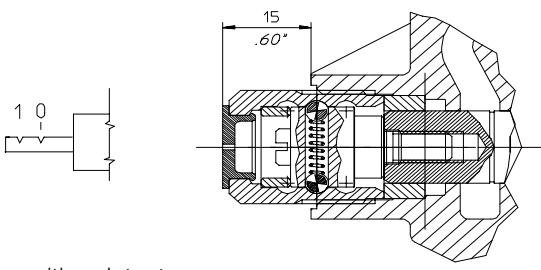

2 position detent

Type 12	Code* 200.7685.1021.0
-------------------	--------------------------

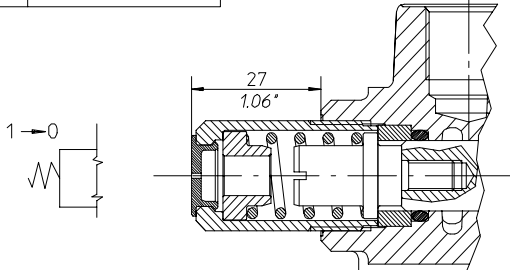

2 position spring return

Type 15	Code* 200.7685.1109.0
-------------------	--------------------------

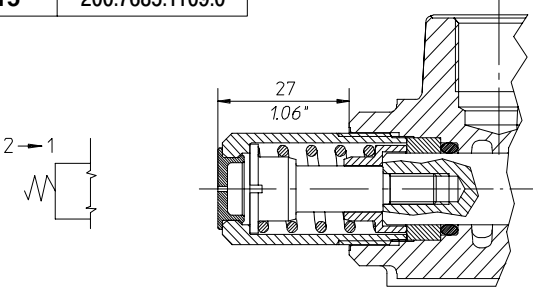

2 position spring return

Type 16	Code* 200.7685.1110.0
-------------------	--------------------------

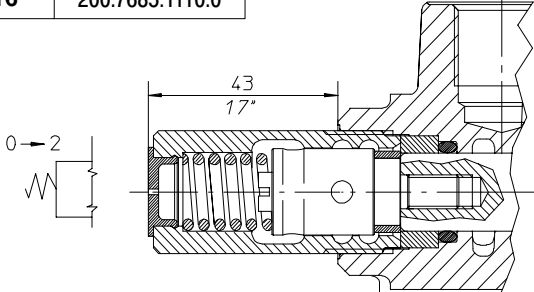

2 position spring return

* : code without plastic plug; plastic plug code: 200.6780.0008.0

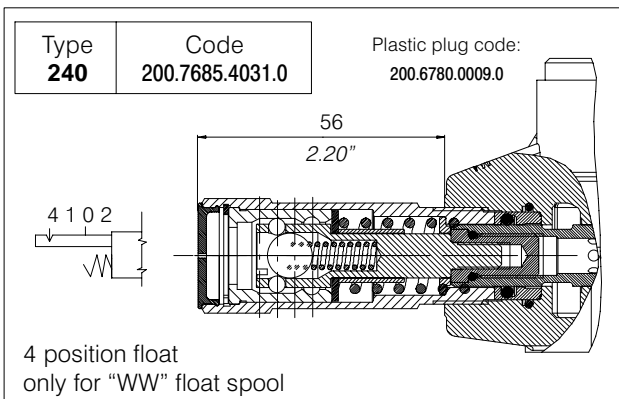
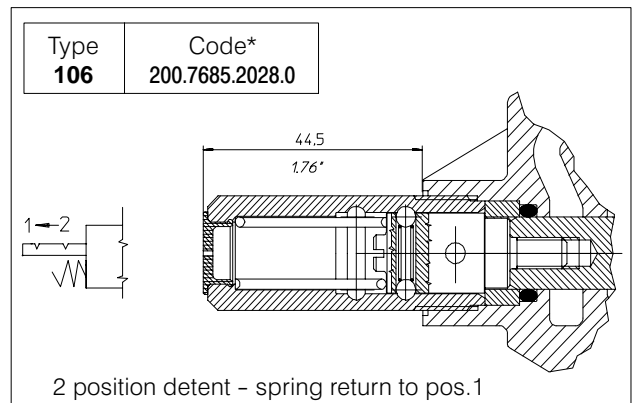
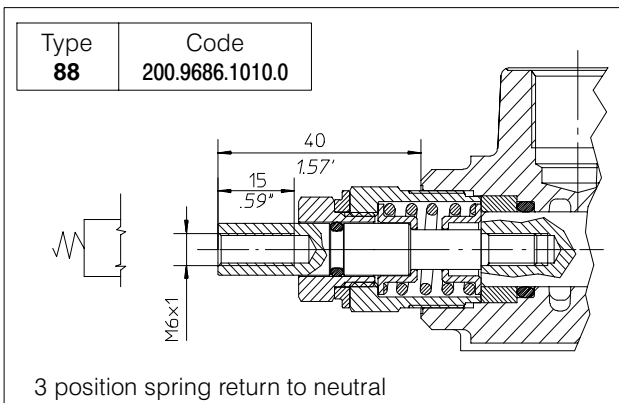
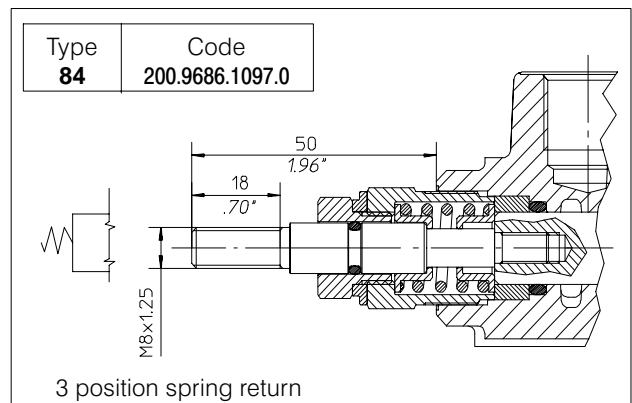
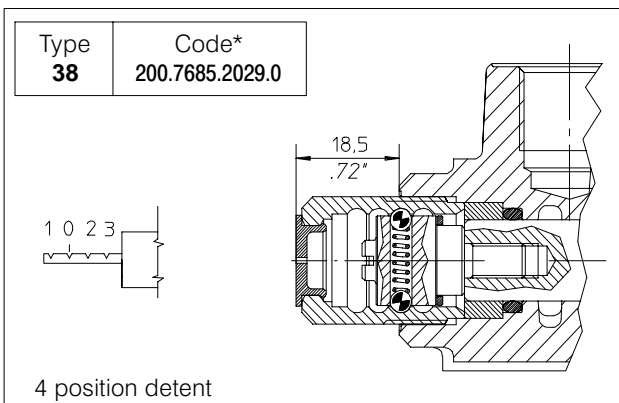
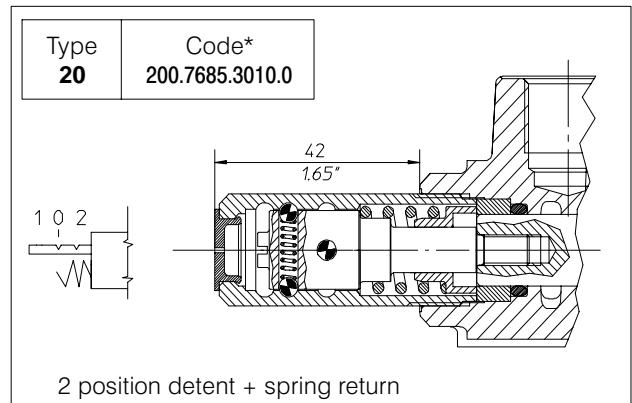
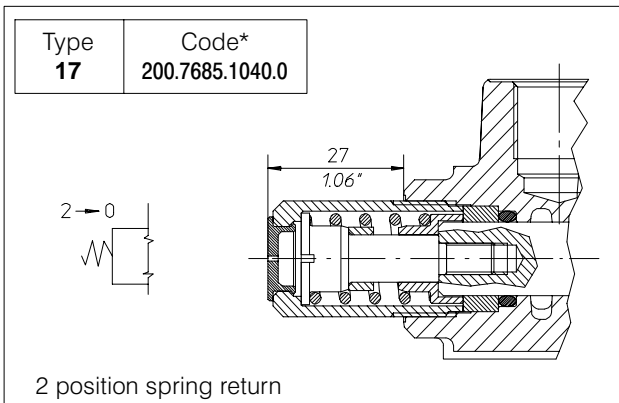

* : code without plastic plug; plastic plug code: 200.6780.0008.0

4.8.1 Microswitch control on each single element

Type 30	Code 200.9686.1050.0	Microswitch is operated when the spool is in pos. 1			
Type 32	Code 200.9686.1060.0	Microswitch is operated when the spool is in pos. 2			
Type 34	Code 200.9686.1064.0	Microswitch is operated when the spool is in pos. 1 and 2			

* The microswitch is supplied only on customer's request.

4.8.2 Single microswitch control for multi-sectional valves (from 1st up to second-last element).

Type 39 (MSF)	Code 200.9686.1139.0			
Microswitch is operated when the spool is in pos. 1 and 2				

4.8.3 Single microswitch control for multi-sectional valves (last element, T side).

Type 40 (MFL)	Code 200.9686.1140.0			
Microswitch is operated when the spool is in pos. 1 and 2				

* The microswitch is supplied only on customer's request.

Positioner 40 must be assembled only on the last element.

4.9 Lever styles

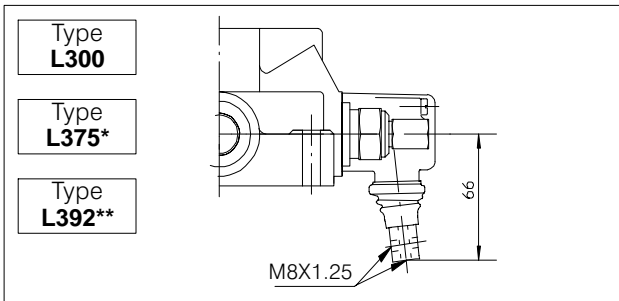
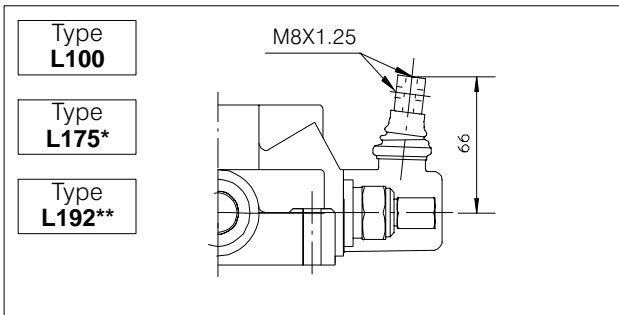
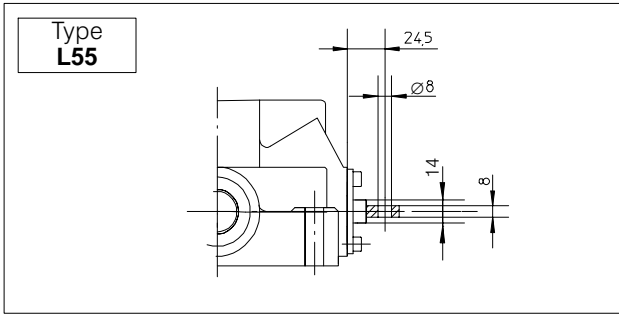

Lo		Type	Code
mm	inches		
150	5.90	AL001	200.7022.1019.0
200	7.87	AL002	200.7022.1003.0
250	9.84	AL003	200.7022.1005.0
300	11.81	AL004	200.7022.1006.0

* L175 - L375 only for "Z" spool application
** L192 - L392 only for "WW" spool application

4.9.1 Safety levers

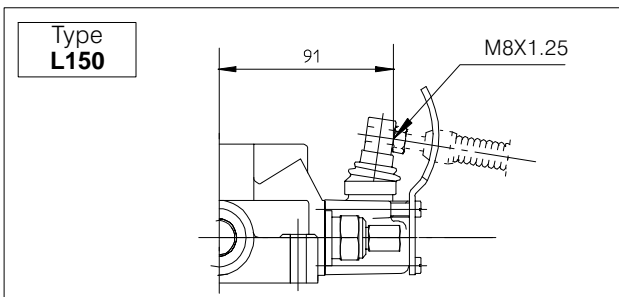
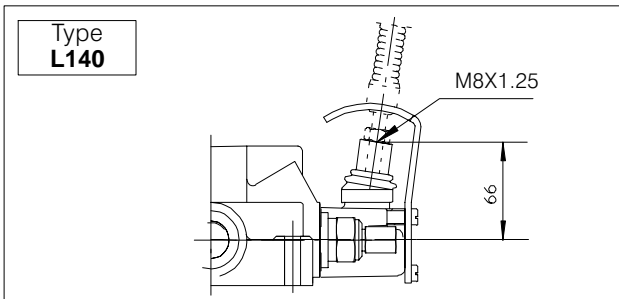

Lo		Type	Code
mm	inches		
160	6.30	AL014	200.7022.1009.0
180	7.08	AL018	200.7022.1011.0

4.9.2 Remote cable control

Lever Support	Code 200.7609.0013.0
----------------------	-------------------------

M10X1.5

Optional 200.6772.0048.0

Lo		Type	Code
mm	inches		
185	7.28	AL001	200.7022.2001.0
250	9.84	AL002	200.7022.2003.0
300	11.81	AL003	200.7022.2004.0
350	13.78	AL004	200.7022.2005.0

Cable	Cable length	Code
--------------	--------------	------

1000 mm	200.5441.04002
1500 mm	200.5441.04005
2000 mm	200.5441.04006
2500 mm	200.5441.04007
3000 mm	200.5441.04008
4000 mm	200.5441.04009

Cables are assembled on the valve only on request and with an extra charge.

Spool Kit

Code 200.9609.0037.0
200.9609.0039.0*

* only for "Z" spool application

Type L142	Code 200.7071.2012.0
------------------	-------------------------

M10X1.5

122
4.8"

42
1.65"

M8x1.25

150
5.9"

35
1.38"

40
1.57"

68
2.68"

40
1.57"

9
.35"

Optional
200.6772.0048.0

Only for rod remote control

Type L218	Code 200.7759.2028.0
------------------	-------------------------

L218 is supplied complete with rubber boot protection

Spool 1 Spool 2

RV

M12

X

① ②

A A A

B B B

View from x

B₁

B₁ B₂

A₂ B₂

A₁ A₂

B₂ A₁

Fulcrum (Bottom left) Fulcrum

X

4.9.3 Cross joystick for dual axis spool control

Type AL010	Code 200.7022.3004.0
-------------------	-------------------------

Lo=250

M12X1.75

4.10 Port relief and anti-cavitation valves

Port relief valve settings

Pressure set range bar (PSI)	Std. setting bar (PSI)	Type	Spring colour
31 - 130 (400 - 1850)	60 (860)	06	Yellow (YE)
131 - 320 (1850 - 4600)	150 (2100)	15	Green (GR)

4.10.1 Port relief valve

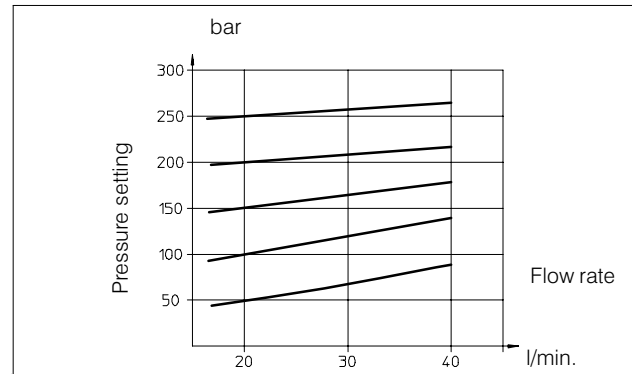
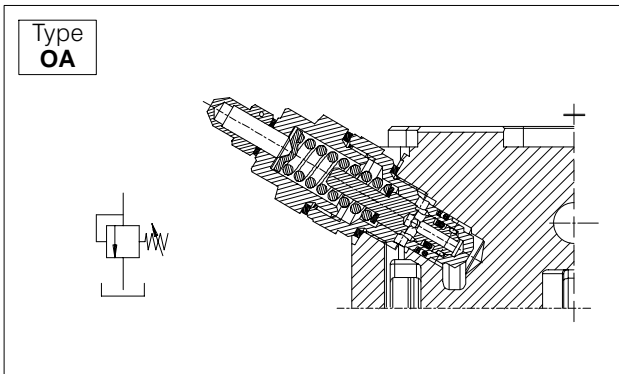

4.10.2 Anti-cavitation valve

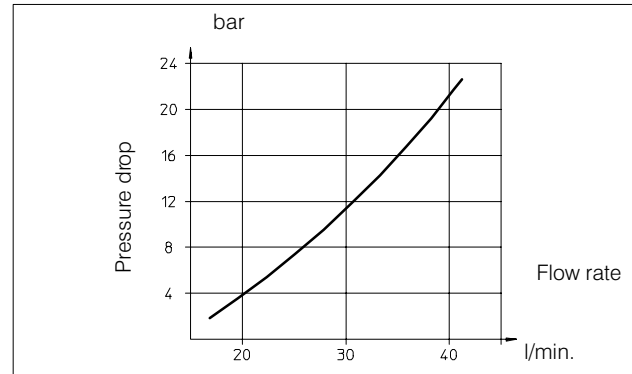
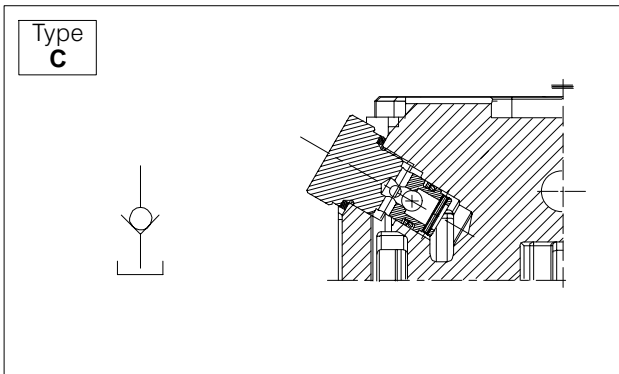

4.10.3 Combined port relief and anti-cavitation valve

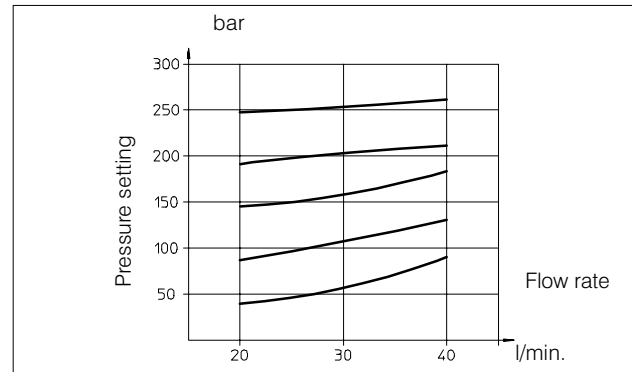
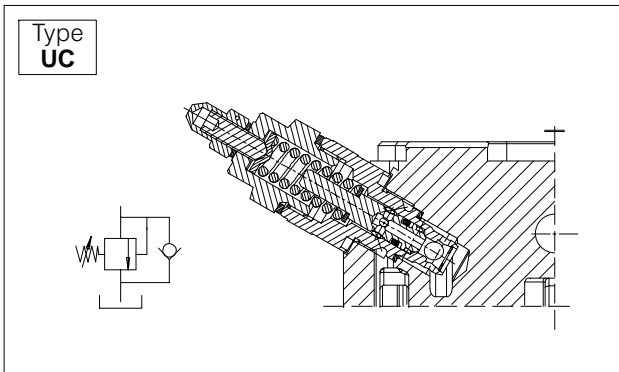

4.11 Hydraulic-Pneumatic control ON-OFF

Type	Code
HP 24	200.9686.5049.0

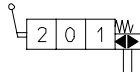

Operating conditions

Hydraulic control:

Pressure range: (bar) Min. 6 - Max. 15
(PSI) Min. 85 - Max. 215

Pneumatic control:

Pressure range: (bar) Min. 6 - Max. 10
(PSI) Min. 85 - Max. 145

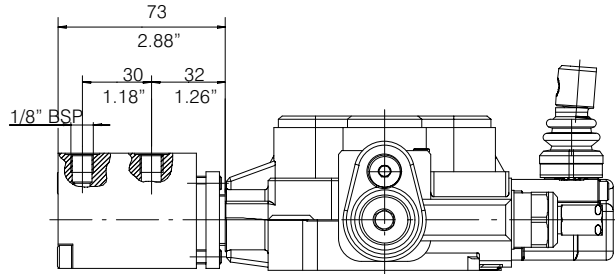

BUCHER HYDRAULICS

www.bucherhydraulics.com

Germany

Phone +49 7742 85 20
Fax +49 7742 71 16
info.de@bucherhydraulics.com

France

Phone +33 389 64 22 44
Fax +33 389 65 28 78
info.fr@bucherhydraulics.com

Netherlands

Phone +31 79 34 26 24 4
Fax +31 79 34 26 28 8
info.nl@bucherhydraulics.com

UK

Phone +44 24 76 35 35 61
Fax +44 24 76 35 35 72
info.uk@bucherhydraulics.com

USA

Phone +1 262 605 82 80
Fax +1 262 605 82 78
info.wi@bucherhydraulics.com

Switzerland

Phone +41 33 67 26 11 1
Fax +41 33 67 26 10 3
info.ch@bucherhydraulics.com

Italy

Phone +39 0522 92 84 11
Fax +39 0522 51 32 11
info.it@bucherhydraulics.com

Austria

Phone +43 6216 44 97
Fax +43 6216 44 97 4
info.at@bucherhydraulics.com

China

Phone +86 10 64 44 32 38
Fax +86 10 64 44 32 35
info.bj@bucherhydraulics.com

Product Center (Elevator)

Phone +41 41 757 03 33
Fax +41 41 755 16 49
info.nh@bucherhydraulics.com

We reserve the right of modification without prior notice.